

Instruction Manual

The "Small Wonder- 40+"

*40 Meter Superhet
Transceiver Kit*



© Copyright 1998, D. Benson. No portion of this document may be reproduced without the express written consent of the author.

Thanks! for purchasing one of the *Small Wonder Labs* "SW-40+" transceiver kits. This kit is an updated version of the classic '40-40' transceiver board which originally appeared in the November '94 issue of QST.

Please take a few moments to look over the section entitled "**First Things First**". This is background information in case you're fairly new to homebrewing or kit-building.

Please- Be sure to read through the "**Building instructions**" portion of this manual before you fire that soldering iron up! That section contains useful information which is key to your success with this kit. Kindly take a few moments to look this material over.

TABLE OF CONTENTS

First Things First.....	2
Materials	3
Parts List	4
Theory of Operation	6
Schematic	8
Pictorial Drawings.....	9
Building instructions	11
Wiring the "SW-40+"	14
Alignment	16
Troubleshooting the "SW-40+"	17
Troubleshooting values	19
Printed-circuit Layout	20

- THE FINE PRINT:

There are lots of small parts in this kit. With many of us getting older, this may prove troublesome. I highly recommend a magnifying glass or close-up glasses to check all solder joints and component codes.

- THE OTHER FINE PRINT:

Despite the care I've put into this manual, it may contain the occasional error. In the event of a conflict between portions of this manual, the following order of precedence applies (most trustworthy first):

- Schematic
- Pictorial
- Parts list
- Everything else

By all means, let me know when you catch these- I do appreciate hearing about them. I add corrective changes immediately because it improves the product!

 Documentation updates are posted on the internet. See <http://reality.sgi.com/adams>, look under 'Elmer101'. If you don't have Web access, contact me by e-mail <bensondj@aol.com>.

TOOLS

You'll need the following tools:

- Soldering iron- 25-40W, solder
- Diagonal cutters
- Needle-nose pliers (helpful)
- Small slot screwdriver
- Magnifying glass (recommended)

TEST EQUIPMENT

You'll need the following:

- DC power source-
12-14V @ 500 mA min.

- Multimeter
- Another transceiver
(for final adjustment)

The following are helpful but not essential:

- Frequency Counter

First Things First - what you should know:

You don't need to be an expert in all phases of this craft, but you should be comfortable with the basics before you embark on this adventure.

- *COLOR CODES:*

You should be familiar with the standard color-code markings on resistors. If not, Radio Shack's Color-Code Guide, #271-1210, will help. If you're not sure, verify the resistor values with an ohm meter. Resistor color codes are given in the parts list.

 For what it's worth, approximately 8% of the male population is red/green color blind. If you're one of these, you should be verifying all resistors with a meter before installing them.

 The SW-40+ board is double-sided and all holes on the board are plated-through. This means that you **do not** need to solder on the top side of the board.

- *SOLDERING SKILLS*

Hopefully this isn't your first experience with a soldering iron. If it is, though, or this is your first solid-state project, here are some tips to ensure your success:

- **Soldering Iron:**

Use a small iron in the 25-watt class (such as a Radio Shack #64-2070) and keep the tip clean. Use a moistened sponge or paper towel to clean the tip periodically as you work.

- Apply only as much heat as is needed to get a good joint. A small vise to hold the printed-circuit board may make soldering easier.

- Touch the soldering iron tip to the PC board trace and the component lead simultaneously. Within a second or two, apply solder and you'll see the solder flow onto the junction. Withdraw the solder and then the soldering iron.

- Avoid the temptation to load solder onto the joint until no more will fit! This is an invitation for trouble, as solder bridges may form across the closer trace separations. Here's what the correct and incorrect joint treatments look like:

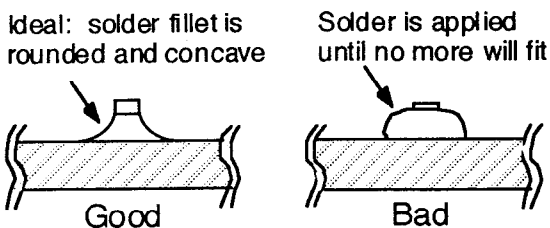

PLEASE READ THE SECTION BELOW BEFORE REMOVING ANY PARTS FROM THE PC BOARD.

Uh-oh! Sooner or later, you may need to remove a part installed in the wrong location, or perhaps pull a component for troubleshooting purposes.

☞ Get yourself a roll of desoldering braid (Radio Shack #64-2090B). Lay the end of the braid down on the joint to be cleaned and press the soldering iron tip over the braid. Within several seconds you'll see the braid begin to wick up solder from the joint. Remove the braid and reapply a new section as needed until the joint is clean. It may be necessary to pull the component out from the top side of the board while heating the joint. Leave the iron tip on the board only as long as necessary to do the job- the PC-board traces will eventually delaminate (peel off) if overheated.

If that still doesn't do the trick, it may be necessary to cut the offending part off on the

top side and pull the remaining leads through with pliers. Contact me for replacement parts if necessary.

☞ If you need to remove a transistor I'd highly recommend sacrificing the part by snipping it off on the top side of the board. The TO-92 pads in particular are small and the leads are best pulled out independently to minimize the risk of lifting pads.

☞ After removing a component from the board, the through-hole will probably still be blocked with solder. Use a dissecting needle, dental probe (explorer) or even a large sewing needle, applying heat to the needle and board trace simultaneously until the tool pushes through.

WINDING TOROIDS:

-Count as you go. Draw each turn snug against the core to ensure a trim and tight winding. Please ensure that none of the turns is wound "over" (on top of) its neighbors.

-Doublecheck the turns count when you're finished. Use your fingernail or small screwdriver to "bump" over each turn as you count- this is much easier than counting by eye.

- Trim the excess wire off to about 1/4" and strip the insulation off with a hobby knife.

Counting the turns:

☞ If the wire passes through the toroid center hole, it counts as a turn.

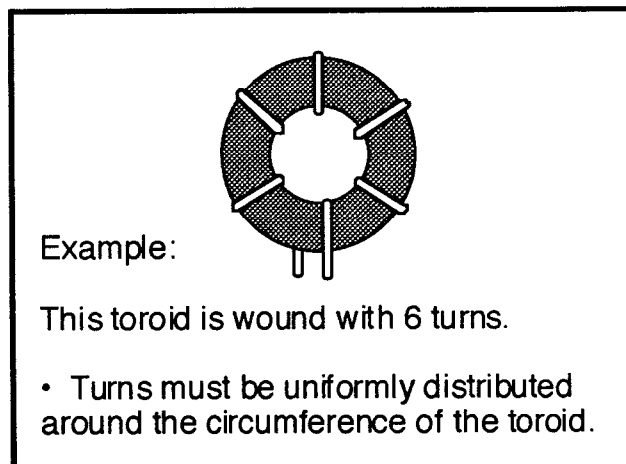

Materials-

You'll find the following items with your SW-40 + kit:

- 1- bag of small parts (resistors, caps, etc)
- 1- antistatic bag (contains semiconductors)
- 1- envelope labeled "MISCELLANEOUS"
- 1- printed circuit board
- (this manual)

The "Miscellaneous" envelope contains the following items:

- 1- 18" (45cm) length of #22 magnet wire
- 1- 3' (1m) length #26 magnet wire
- 1- 6" (15cm) length insulated wire
- 3- RF Chokes
- 2- Zener Diodes

 Keep the RF Chokes in this envelope until you're ready to use them. This way, they're less likely to be confused with resistors.

• (You may want to reproduce the schematic and layout pages so you can mark on them as you work, and still keep the original neat and clean.)

Reference designators:

Each component is uniquely identified by a reference designator. Bypass capacitors are identified as C100 and up.

"C7":

Capacitor C7 is a assortment of 6 different capacitors designated C7A through C7F, it replaces a trimmer cap found on the original SW-40. Selection and installation of this cap is described later in the text.

Monolithic caps:

The printing on these parts is tiny! I'd highly recommend using a magnifying glass to verify component values before installing them.

• IF Transformers:

Although not illustrated on the schematic drawing for reasons of drawing clarity, T1-T3 contain internal capacitors. Do not remove these capacitors.

Special Parts Notes:

Parts List- "SW-40+" Transceiver

Qty	Ref. Desig.	Description	Identification
2	C3,C9	10 pF ceramic disk	'10'
1	C7A	22 pF NPO cer. disk	'22'
9	C2,7B,11,17,18,28,30,32,40	47 pF NPO cer. disk	'47'
3	C1, C7C,16	68 pF NPO cer. disk	'68'
2	C7D,C8	82 pF NPO cer. disk	'82'
1	C7E	100 pF NPO mono. cap	epoxy, '101J'
1	C7F	120 pF NPO mono. cap	epoxy, '121J'
1	C7G	150 pF NPO mono. cap	epoxy, '151J'
7	C12-15,22,23,29	150 pF ceramic disk	'151J'
1	C31	220 pF ceramic disk	'221J'
1	C10	270 pF ceramic disk	'271J'
2	C37,39	470 pF ceramic disk	'471J'
1	C25	820 pF ceramic disk	'821J'
1	C38	1000 pF NPO mono. cap	epoxy, '102J'
2	C4,5	2700 pF NPO mono. cap	epoxy, '272J'
1	C6	3300 pF NPO mono. cap	epoxy, '332J'

Parts List- (cont'd)

Qty	Ref. Desig.	Description	Identification
1	C26	.0022 uF disk or mylar cap	"222K"
11	C21,33-35,102-105, 108,109,111	.01 uF ceramic disk	"103M"
1	C19	.033 uF disk or monolithic cap	"333K "
7	C20,24,36,101,107,113,114	0.1 uF monolithic cap	epoxy, "104"
1	C110	3.3 uF 50V radial Elec. Cap	<i>banded end is negative</i>
2	C27,106	47 uF 16 V radial Elec. Cap	" " " "
1	C112	220 uF 16V radial Elec. Cap	" " " "
1	D1	MV1662 Varicap diode	TO-92, 2 leads, stripes only
9	D2-10	1N4148A diode	glass body
1	D11	7.5V 0.5W 5% Zener Diode	1N5236
1	D12	33 V 0.5W 5% Zener Diode	1N5257
1	D13	1N4001 diode	black case
1	L1	T-50-6, <i>see text, p. 12</i>	0.50" dia, yellow
1	L2	FT37-43, 6 turns	0.37" dia, dark grey
2	L3, L4	T-37-2, 1.0 uH, 16T #26	0.37" dia., red
1	Q1	MPF102	plastic-cased (TO-92)
1	Q3	2N3906	plastic-cased (TO-92)
3	Q2,Q4, Q5	2N4401 or equiv. <i>(may be house #- marked)</i>	plastic-cased (TO-92)
1	Q6	2SC2078	TO-220 device
2	RFC1,RFC2	22 uH 5% RF Choke	Red-Red-Black-Gold
1	RFC3	10uH 5% RF Choke	Brwn-Blk-Blk-Gold
1	R24	500Ω trim pot	White plastic, 3 leads
3	R6,14,27	10Ω 1/4W 5% resistor	Brn-Blk-Blk-Gold
2	R28,29	51Ω 1/4W 5% resistor	Green-Brown-Blk-Gold
2	R1,26	470Ω 1/4W 5% resistor	Yellow-Viol.-Brn-Gold
1	R19	1KΩ 1/4W 5% resistor	Brn-Blk-Red-Gold
2	R17,25	2.2KΩ 1/4W 5% resistor	Red-Red-Red-Gold
4	R2,3,21,22	10KΩ 1/4W 5% resistor	Brn-Blk-Orange-Gold
4	R10,16,20,23	22KΩ 1/4W 5% resistor	Red-Red-Orange-Gold
1	R15	47KΩ 1/4W 5% resistor	Yellow-Viol.-Orange-Gold
3	R4,7,11	510KΩ 1/4W 5% resistor	Green-Brown-Yellow-Gold
4	R8,12,13,18	1MΩ 1/4W 5% resistor	Brn-Blk-Green-Gold
1	R9	4.7MΩ 1/4W 5% resistor	Yellow-Viol.-Green-Gold
4	S1-S4	8-pin low-profile IC socket	
3	T1-T3	10.7 Mhz IF transformer	"421F123"
1	T4	FT37-43, 8T:1T, <i>see text</i>	0.37" dia., dark grey
1	U2	78L08 voltage regulator	plastic-cased (TO-92)
3	U1,U3,U5	NE602AN, NE612AN, SA602AN or SA612AN	8-pin IC
1	U4	NE5532	8-pin IC
5	Y1-Y5	4.00 or 4.032 Mhz crystal	HC-18/U holder, 20pF

Theory of operation

This transceiver is a single PC-board design measuring 2.8" x 4.0" (7 x 10 cm). It features VFO operation with a 35-40 KHz tuning range, as well as QSK (full break-in) operation. Let's take the 50-cent tour:

The receiver RF input is applied to U1 through T1 and C1, which provide a bandpass filter tuned to 7.0 Mhz. T1's secondary winding provides roughly unity-gain into U1 to minimize overload (IMD). U1 provides about 13 dB of gain in this configuration, and converts the RF input to the IF frequency of 4.0 Mhz. The L-network (C11 and RFC1) following the mixer serve to step the mixer output impedance down to the crystal filter's design value. *Note that C12 and RFC1 appear to be 'transposed', this reflects the board's physical layout.*

The crystal filter itself uses 3 crystals. This works well because of the choice of a low IF frequency. Loss through the filter is less than 2 dB, and with the component values shown, the -6dB bandwidth is about 500 Hz. Despite the filter's low parts count, performance is adequate when combined with the AF section's selectivity. The unwanted sideband image is down about 50 dB at the audio chain's 800 Hz peak response frequency.

The filter output is terminated in a 470Ω resistor at the input to U3, the product detector stage. U3 converts the 4.0 Mhz IF signal to audio and contributes another 13 dB of gain. BFO crystal Y3 has been selected to match the IF filter frequency, so there's no BFO frequency trimming needed. The .033 uF capacitor across pins 4 and 5 of U3 provides the first measure of audio low-pass filtering.

The two sections of U4 each provide roughly 30 dB of amplification. The first section is configured as a differential amplifier to make use of U3's differential output and rolls off the audio response above 1.5 khz. Diodes D3 and D4 serve to limit the audio swing during transmitter key-down to reasonable values. Without these diodes, this stage saturates and upsets the operation of the following FET switch section.

The AF mute function is the familiar series FET switch popularized by W7EL. Despite its relative simplicity, it's hard to beat this circuit for click-free audio switching. In the "key-up" condition the FET is "zero-biased" and acts like a resistance of several hundred ohms. In the "key-down" condition the FET is in cutoff (because the gate is now 7-8 volts below the source) and acts like an open-circuit, preventing audio from getting to U4B, the audio final stage. This stage is configured as a bandpass filter centered at 800 Hz. The high gain of the two NE5532 stages (64 dB total) allows a design with no IF amp stage. The audio output level is adequate to drive headphones, but it won't do the job for loudspeaker applications. The AF output stage internally overcurrent-limits on loud signals to provide a ready-made ear protection function. (In this respect, it accomplishes what you'd want an AGC for anyway.) If you're interested in saving at least 5 milliamps on receive, U4 may be replaced by an LMC662 (available from Digikey). This suggestion is courtesy of Mitch Lee and Dennis Monticelli, from their excellent article, "Revisiting the 40-40" in the ARRL's 'QRP Power'.) *Use good quality low-impedance headphones for best results. "Walk-man"-headphones are fine, but remember- you get what you pay for- the 3-dollar bargains are distinctly inferior!*

QSK: The T-R switch function is provided by C40 and RFC3, which form a series-resonant circuit. Diodes D7-D10 limit during key-down and thereby restrict the signal levels presented to the receiver front-end during transmit. *The double-diode configuration raises the network's intercept point with respect to W7EL's original configuration to improve IMD immunity.*

The LO uses the Colpitts configuration. The frequency-determining capacitors are NPO (C0G) monolithic types. These devices are extremely compact and offer good temperature stability. C2 and C3 are a voltage divider providing proper injection to U1, *Note: If you want broader frequency coverage, the value of C8 may be increased. The useful upper limit for C8 is about 1000 pF, and especially at the larger values, capacitor (and varicap diode D1) thermal stability will become crucial. Use NPO /C0G capacitors if possible if you tinker with this circuit.*

The design also uses a varicap tuning diode for tuning coverage. While a smooth ball-bearing tuning cap and vernier reduction drive are the preferred approach, that choice drives the cost and mechanical complexity of a transceiver up considerably. The varicap approach supports quite a compact package! If you've just got to have RIT, an outboard circuit which injects an adjustable DC offset into the diode bias network on receive does the trick.

The transmitter chain is a pretty standard affair. The maximum output power is about 2-2.5 watts and there's a drive control at the

emitter follower stage (Q4) to adjust the output level. The diode the base of Q6 serves to 'clamp' the signal to Q6 above ground and thus improves drive to the PA by several dB. *I don't feel that the PA requires a heat sink at the 1.5-2.5W power level and CW duty cycles. If you like, there's room for a 'compact'-style T0-220 heat sink (Digikey #HS-105 or HS-106).*

This rig complies with the FCC requirements for spurious emissions. All harmonics were down at least 34 dB. The largest spurious output was down at least 46 dB.

Here's a summary of the changes incorporated in this version of the SW-40:

- Added power supply reverse-polarity diode.
- The receiver front end is reworked to eliminate the original multiple-winding toroid.
- The diode bridge T-R switch is replaced by a series L-C type. This drops resting power supply current from 22 to 16 mA and significantly improves image rejection.
- The crystal filter grew from 2 to 3 crystals and changed to a Cohn filter configuration. A grounding point for the crystal cases is also provided to reduce filter 'blow-by'.
- Eliminated LO trimmer capacitor and replaced with pads for select assortment. Replaced polystyrene caps with C0G monolithic caps for improved reliability.
- Changed the TX bandpass filter to use IF transformers. This configuration makes use of the differential outputs of the NE612. Filter bandwidth is increased considerable over the original configuration.
- The PA is a T0-220 device, capable of considerably more output power than the original. This change was made to eliminate the TO-5/TO-39 device packaging, which is becoming increasingly difficult to find.
- Improved functional grouping of interconnect. The companion enclosure kit provides locking .100" headers, with pre-assembled harnesses.

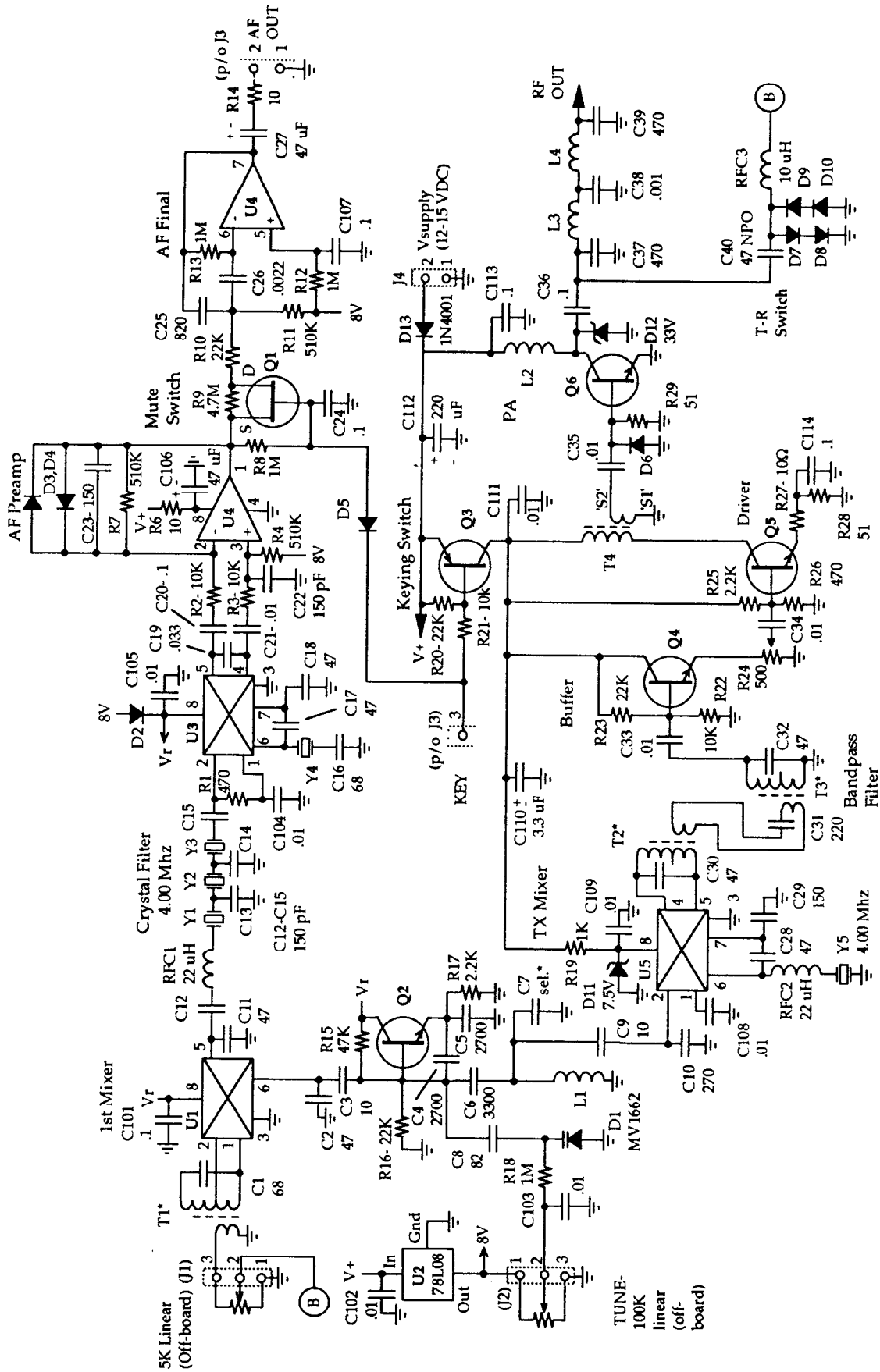

The "SW-40+" Transceiver

SMALL WONDER LABS™
10/2/98

* T1-T3
C-internal not shown,
leads intact.

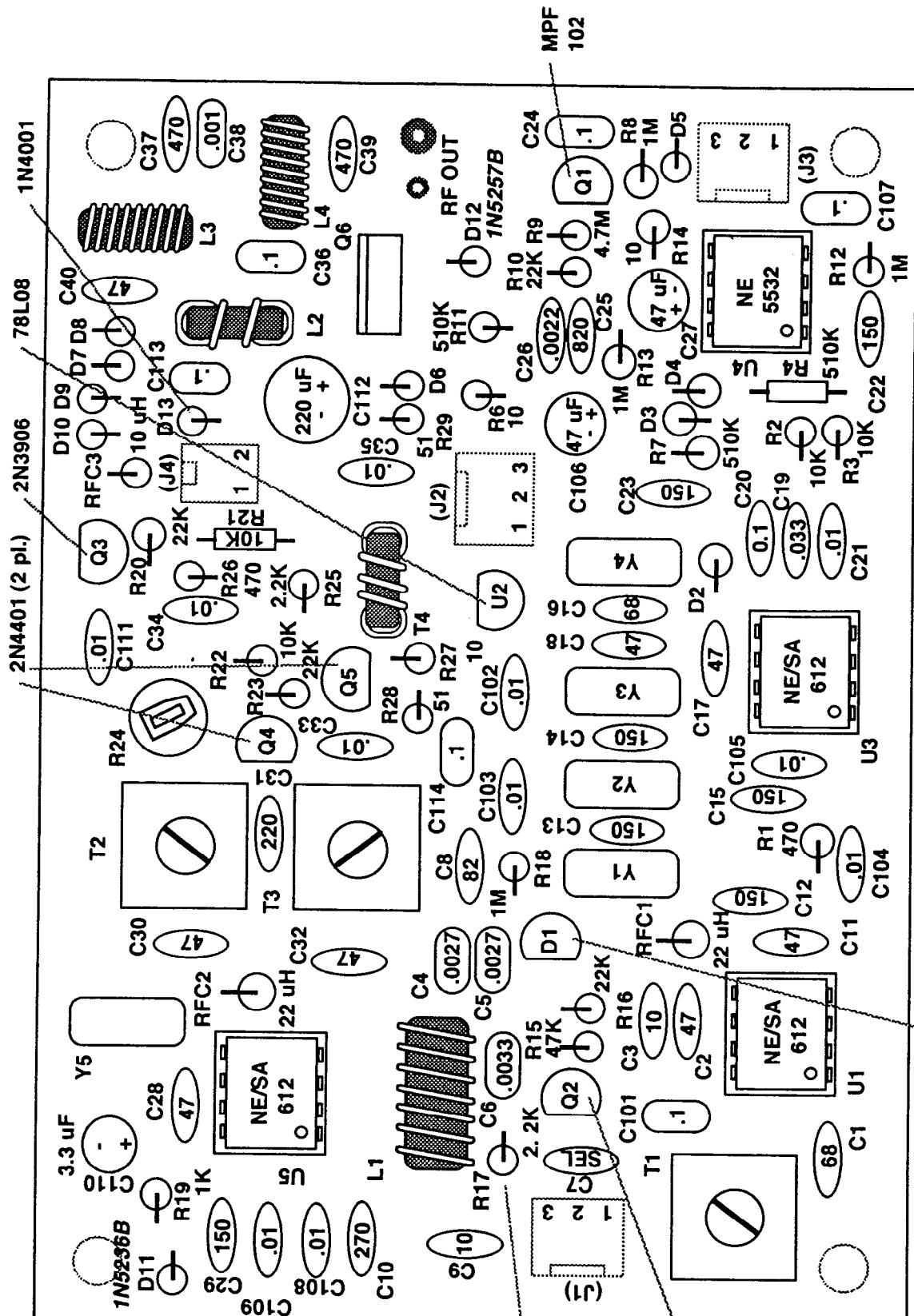

Orient as shown - (silkscreen is in error)

2N 4401

MV1662

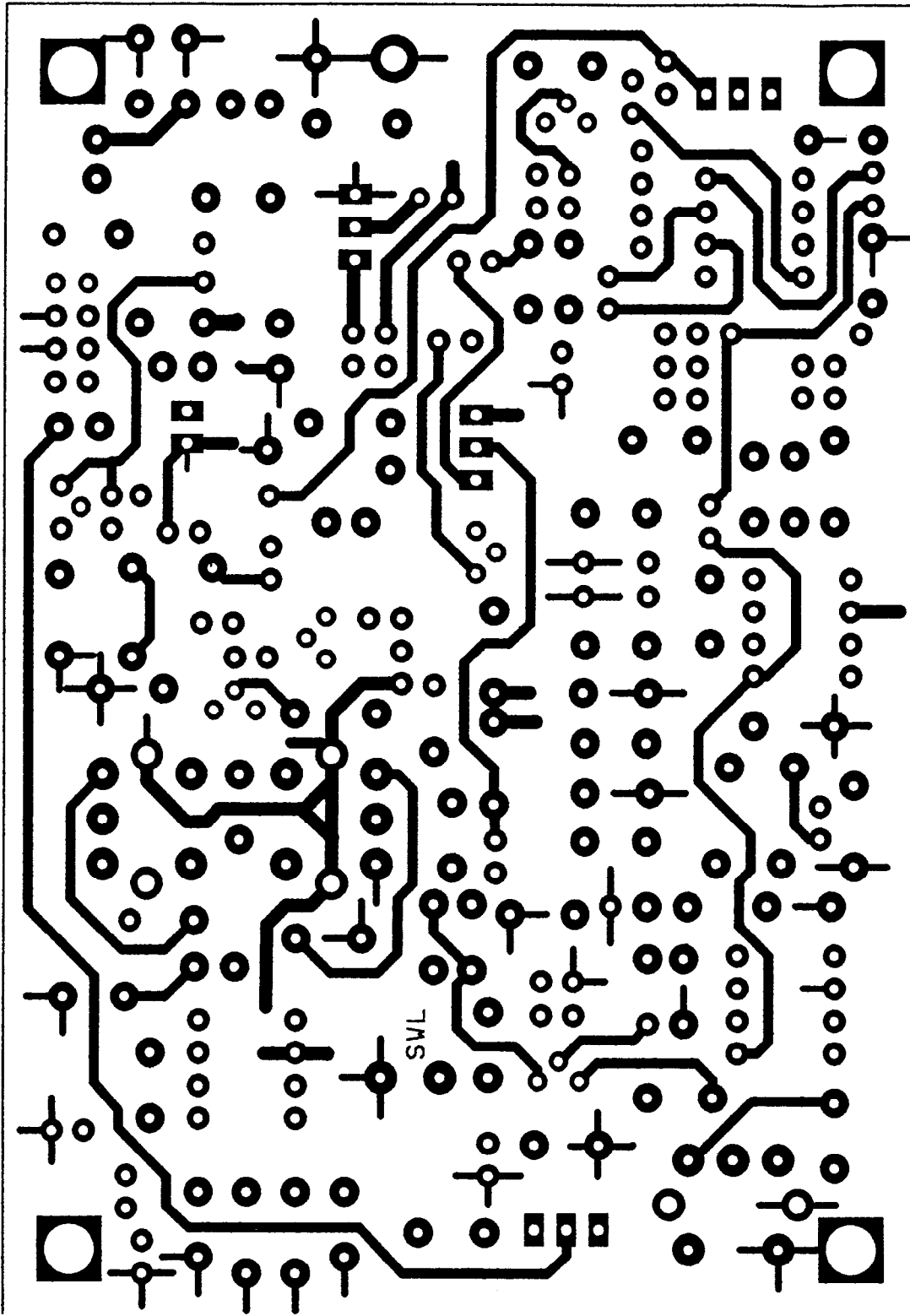

(ground plane areas not shown)

Building instructions:

- All parts installed on the PC board should be fully seated. Do not install the parts in "flying-lead" fashion in the hope that it will improve something-or-other! Minimum lead length is important to a successful RF design.

Diode Installation:

All diodes except D1 are bent for "upright" installation on the board. Installation polarity is as shown below. Be sure to note the orientation of the silkscreened circle on the board and install the diode body over this hole. The cathode (banded) end of the diode is oriented at the top.

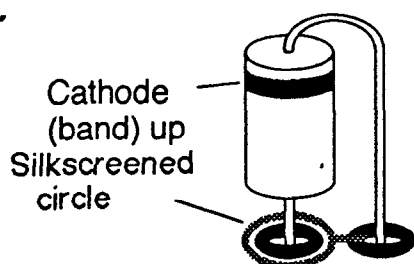

Resistor installation:

All resistors except R4 and R21 are likewise installed in 'hairpin' fashion. As with the diodes, try to match the mounting orientation shown on the drawing. (This usually has nothing to do with critical dimensions- if mounted as shown you've got better troubleshooting access to circuit points from the top side of the board.) Orientation of resistor (and other nonpolar device) color bands is non-critical.

Installing IC sockets:

The "notch" or dot at one end should be oriented as shown in the pictorial drawings. *Doublecheck orientation before soldering.* A suggestion- solder down two opposite corners of each socket, and then go back and press a fingertip on the socket from underneath while reheating both connections in turn. You may then solder the remaining pads. This precaution ensures that the socket is well-seated on the PC board.

Some additional tips:

- It's helpful to work from one end or corner of the board to the other. This minimizes the "tight

squeeze" cases where the last part in a cluster has to drop into a tight space.

- Stuff only a few parts at a time (3-4 pieces). If you try to add too many parts at once between soldering operations, you may lose track and wind up with missing solder joints! Once you've stuffed the parts on the board, bend the protruding leads slightly outward to keep them in place while the board is inverted for soldering.

- Some of the disk and monolithic capacitors may be supplied with a lead spacing of 0.10" (2.5mm). The "SW-40+" has generally been laid out for a 0.20" capacitor spacing. The capacitor leads may be gently spread apart near the component bodies and then bent parallel to ease installation.

Recommended Assembly sequence:

I've specified the sequence below, but there's nothing sacred about the order in which the board is populated. Some parts are best installed in a particular order, as noted within each group's instructions.

- Directions for winding toroids are found within each group's assembly instructions.

(The figures which follow are for reference only. See the pictorial drawing on p. 9 for component values.)

[] Install D13, U2, C102 and C113. *If you have the companion enclosure kit, install connectors J4 (2-pin) and J2 (3-pin) as well. This step supplies DC power to the board and installs the 8 Volt regulator IC.*

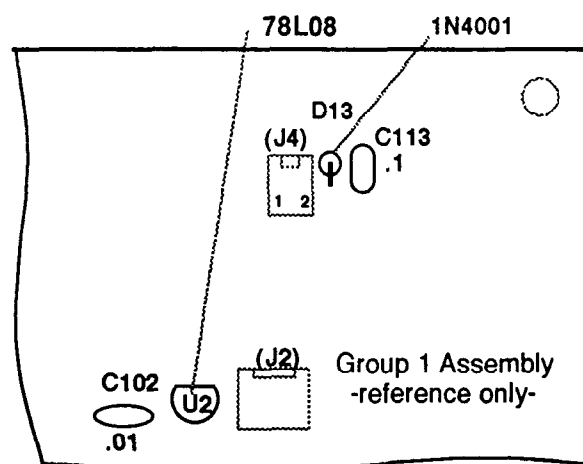

- [] Install an 8-pin IC socket at U4.
- [] Install the components shown below:

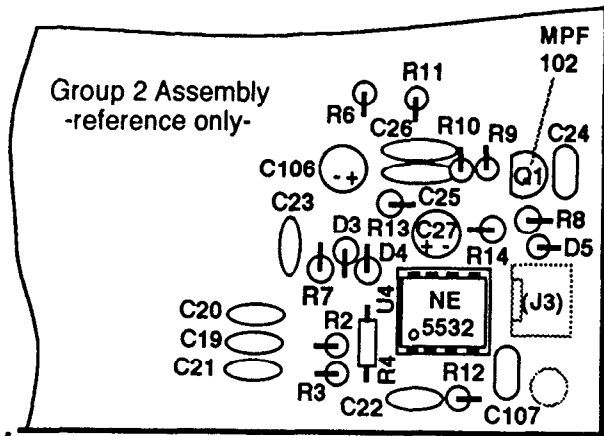

(When these components have been installed, the audio amplifier section of the transceiver is complete.)

- [] Install an 8-pin IC socket at U3.
- [] Install the components shown below:

Note: the 5 crystals supplied with this kit have been preselected as a group. They are interchangeable within this group. Do not, however, substitute replacement parts- contact me for assistance.

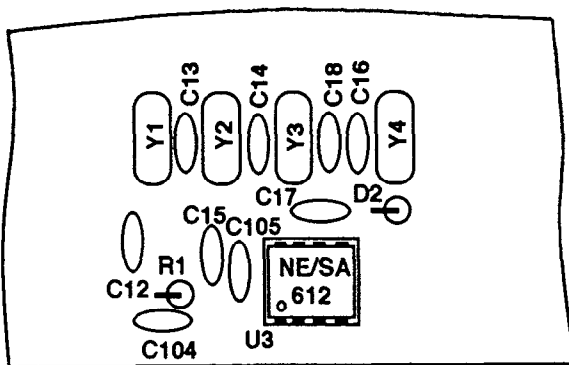

Group 3 Assembly
-reference only-

(When these components have been installed, the product detector/BFO and crystal filter sections of the transceiver are complete.)

- [] Install an 8-pin IC socket at U1.

Install the components shown below:

- L1 (yellow core) is wound using the larger-diameter magnet wire from the "Misc" envelope. Wind with 25 turns (24 turns for Novice-band operation), prepare lead ends and install on the board. All other toroids use the smaller diameter wire.

☞ C7 is not installed at this time, see "Alignment" for installation procedure.

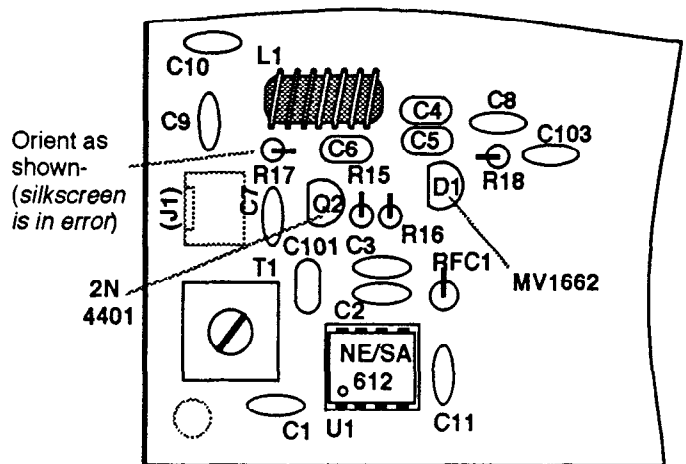

Group 4 assembly
-reference only-

(When these components have been installed, the receiver portion of the transceiver is complete.)

- [] Install an 8-pin IC socket at U5.
- [] Install the components shown below:

The following components are polarity-sensitive:

D11, C110, Q3-Q5

 Spacing on C31 (between transformers T2 and T3) is quite tight- install this capacitor prior to installing T2 and T3.

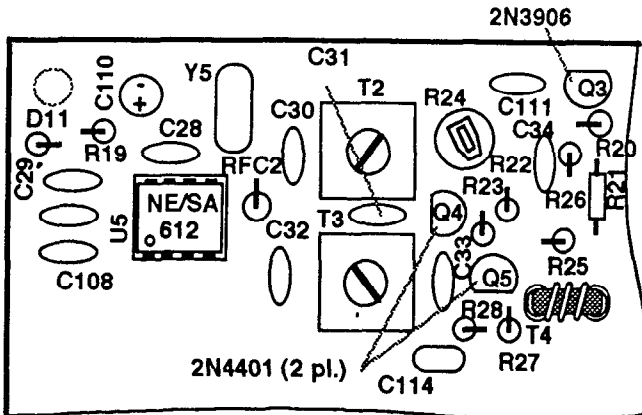

Group 5 assembly
-reference only-

- Transformer T4 (grey core) is wound with 4" (10 cm) of magnet wire for the primary winding. The primary winding is wound first, using 8 turns. Install T4.

[] Add a secondary winding to T4 as follows:

1) Strip 1/8" of insulation from one end of the 3" length of insulated wire. Twist the wire gently between your fingertips to ensure that all strands are bundled together. Tin this lead-end with solder.

2) Install this lead-end in S2 and solder.

3) Take the free end of this wire in the direction of S1 and then double it back through the hole in T4.

4) Draw the lead snug (not tight!) and proceed around the toroid material

until you've formed one complete turn through the toroid as shown below:

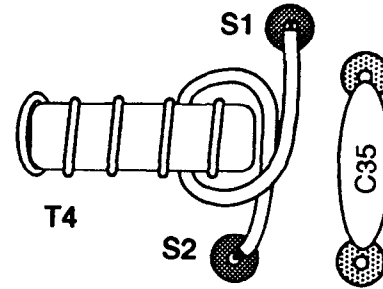

detail- T4 secondary winding

5) Trim off the free end of the wire so that it has about 1/4" (6mm) more than is needed to reach pad S1. Repeat the lead preparation as in step 1 above.

6) Install this lead-end in S1 and solder.

(When these components have been installed, the transmitter mixer, bandpass filter and driver sections of the transceiver are complete.)

[] Install the components shown below

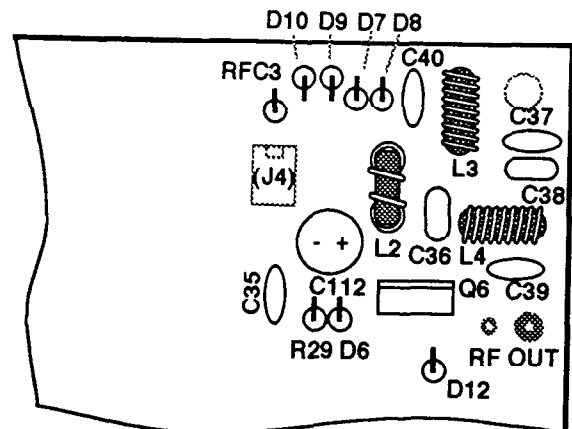

Group 6 assembly
-reference only-

The following components are polarity-sensitive:

C112, D6-D10, D12, Q6

 Q6 (2SC2078) is installed with the metal tab to the rear (or 'top', when viewed from directly overhead). When viewing the board from the front edge (U1, U3 and U4 nearest you), Q6's labeling must be viewable

- L2 is wound using 4" (10 cm) of wire on an FT37-43 (grey) core. Wind 6 turns on this core, prepare lead ends and install on the board.

- L3 and L4 are each is wound using 10" (25 cm) of wire on an T37-2 (red) core. Wind each with 16 turns, prepare lead ends and install each of these on the board.

(When these components have been installed, the board assembly is complete.)

If you have not already done so, install all integrated circuits on the board as indicated on page 9. Be sure that the ICs are oriented properly - the dot or notch is on the left side of the 8-pin DIP ICs as viewed on the pictorial.

CLEAN UP YOUR ACT! Before you install the finished PC board into an

enclosure, grab some cotton swabs and use acetone (nail polish remover) to remove solder flux from the foil-side of the PC board. The result is a much cleaner appearance once you've completed this step.

Wiring the SW-40+:

The figure below show the schematic interconnect between the SW-40+ board and the outside world (more on alignment later).

Short, direct leads between the "SW-40+" board and your connectors and controls are advisable. If you're going to run the RF output more than a couple of inches to an antenna jack, coax (such as the subminiature RG-174) is recommended. The other interconnect wiring is less critical, but try to avoid routing the wiring over the audio (U4) filter section if possible.

• The companion enclosure kit includes .100" header strips and mating connectors with pre-assembled harness. Install these if you have that kit. (Contact me if you'd like further information on that kit.)

• If you have just the board kit, proceed to wire directly to the 'J-series' locations.

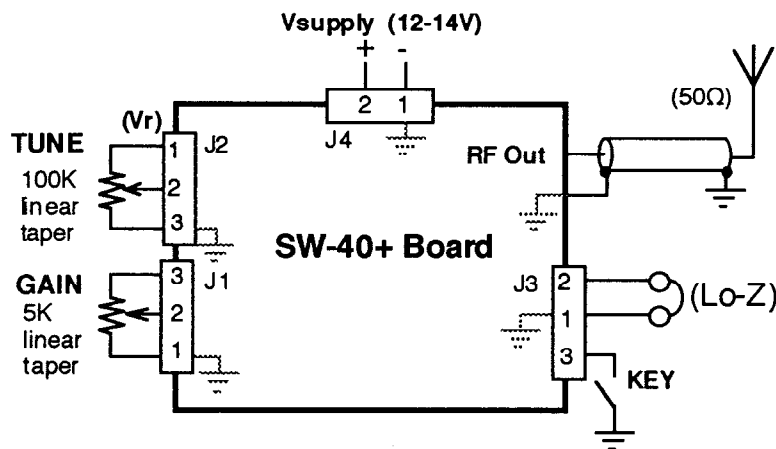

Wire the connectors and controls to the SW-40+ as shown pictorially below. Note that the keying return line lacks its own distinct board connection. This return line is shared with the headphone's return.

STOP!

"SW-40+" Mechanical Details

The pictorial figure below shows some ideas for connectors and their accompanying mounting hole diameters. These are merely suggestions and are a matter of personal preference.

The board itself is mounted in an enclosure at the board's four corners, using #4 machine screw hardware. #4 spacers should be used to separate the PC board from the enclosure

Before you progress to the next phase of this project, this might be a good time to check out the "SW-40+". Add the various connectors and controls using temporary leads before you get the project buttoned up in a box. If you need to do any troubleshooting, you'll have saved the aggravation of having to undo all the wiring to get at the bottom side of the board!

by 3/16" or more. (#4 hex nuts are an acceptable substitute for spacers.)

Enclosures may be found in a variety of styles. Radio Shack offers several types of metallic enclosures. I'd especially recommend Hosfelt Electronics, Inc., who carry enclosures offered by a number of companies. There's no minimum order, and they can be reached at [800] 524-6464 for a catalog. Ten-Tec also offers a complete line of enclosures, and they support small orders as well! Call [800] 231-8842 for a free brochure.

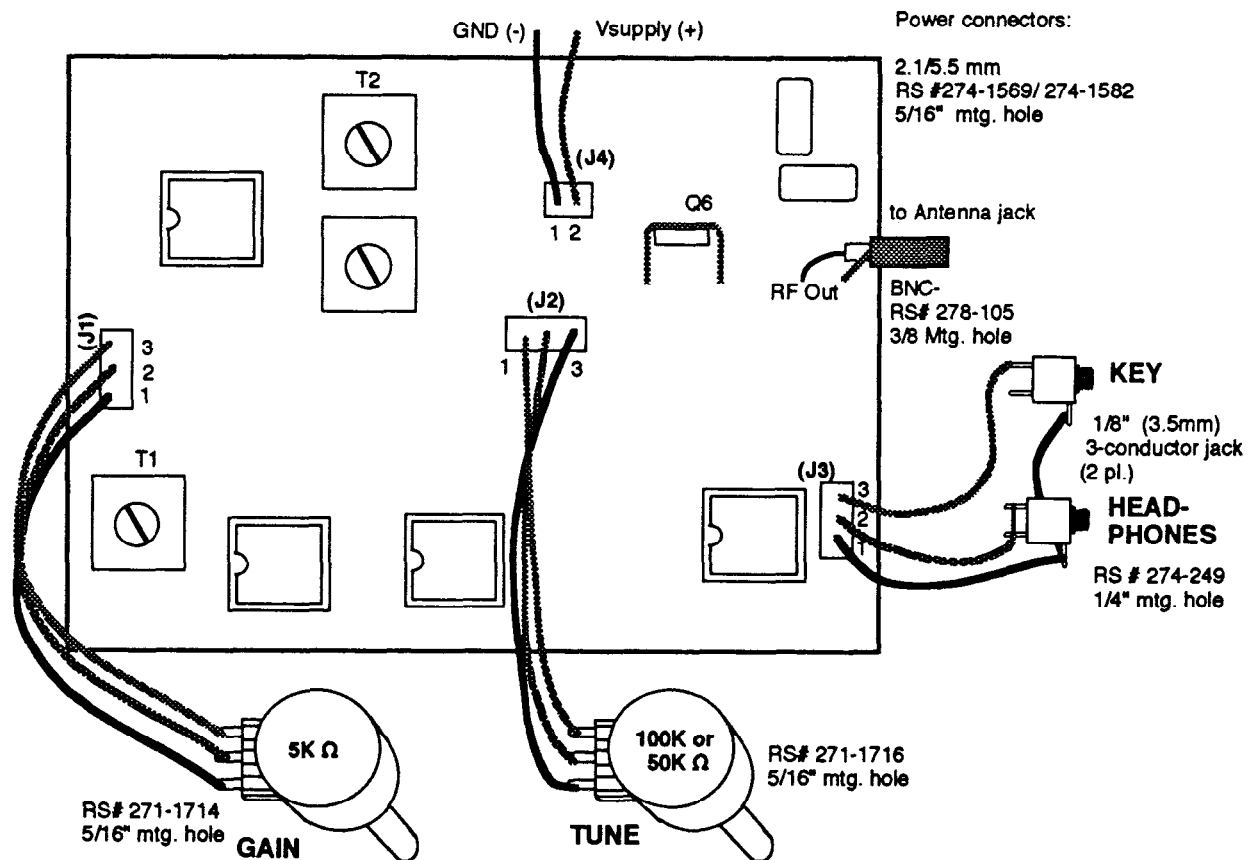

Before the "Smoke Test":

- Inspect your work to ensure there are no solder bridges or unsoldered joints. Check to see that the ICs are mounted in their proper orientations.

Alignment:

Alignment is easy with this little rig. For test equipment, you'll need a main-station rig and multimeter or SWR bridge. Here's how:

Transmitter alignment:

[] Connect a tuning pot to J2. (See page 13 for interconnect pictorial.) Set the tuning pot to full counterclockwise (0V on the pot's center terminal).

[] Connect a 50-ohm dummy load to 'RF Out' and its adjoining ground return pad.

[] Set trimmer R24 to the halfscale ('3 o'clock') position.

[] Using a small slot screwdriver, preset the tuning slugs in T2 and T3 to the middle of their rotation range. (*This is non-critical, there's no need to count turns!*)

[] Add a clip lead to R29 (see figure below) to serve as a short whip antenna. (Leave the other end of the clip lead unconnected, and ensure that this free end is well away from other circuitry.)

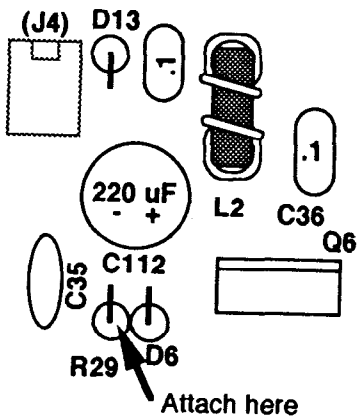

[] Apply DC power (J4)

[] Ground the "Key" (J3-3) input.

[] Tune in your transmitted signal on your "big rig" receiver. This should be a strong carrier (S9+20 or better).

Be sure to hunt for the strongest signal over a range of 7.0 to 7.3 Mhz to ensure that you find the primary signal instead of a receiver spurious response.

Operating frequency adjustment

[] Note the frequency from the step above. Remove power and install a value of C7 in accordance with one of the tables below:

• For 7-7.05 Mhz operation:

If the frequency was between:	Install the following value for C7
7000-7030	(none)
7030-7060	22 pF
7060-7090	47 pF
7090-7120	68 pF
7120-7140	82 pF
7140-7160	100 pF
7160-7180	120 pF
7180-7210	150 pF

• For 7.1-7.15 Mhz (Novice) operation:

If the frequency was between:	Install the following value for C7
7100-7130	(none)
7130-7160	22 pF
7160-7190	47 pF
7190-7220	68 pF
7220-7240	82 pF
7240-7260	100 pF
7260-7280	120 pF
7280-7310	150 pF

(The approximate formula for the value of C7 is as follows:)

$$[C7] \text{ (in pF)} = \Delta f \text{ (kHz)} / 1.42$$

where Δf is the desired frequency shift.

It's possible to adjust the operating frequency as much as 15-20 KHz downward by squeezing L1's turns more closely together. If in doubt which of two values of C7 to use, install the smaller of the two and compress L1's turns as needed.

Connect the RF output to a wattmeter (if you have one). You can also use your SWR meter with a dummy load connected and set in the "Forward" metering position.

If you don't have either of these pieces of equipment, you can 'haywire' the test circuit below on a scrap of copper clad board. This peak detector circuit furnishes a DC voltage to your multimeter.)

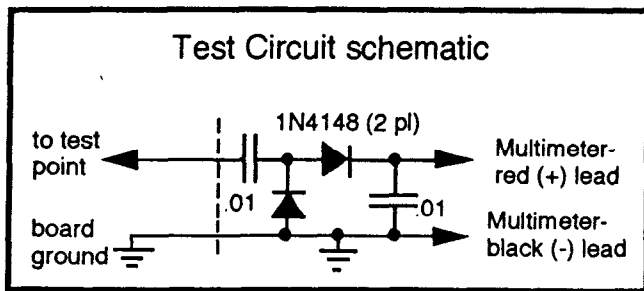

Adjust T2 and T3 for maximum indicated signal on your receiver's S-meter. The

adjustment will be somewhat interactive, so alternate between the two for maximum output.

- (Remove the clip lead.) Adjust trimmer R24 as needed for 1.5 watts key-down power into a dummy load or the test circuit shown on the previous page. (For the test circuit above, this corresponds to a DVM measurement of 12V DC). Increase drive (R24 clockwise) only as needed to get to this level.

Receiver alignment

- Connect a matched antenna to "RF Out" and its ground return. Using a small slot screwdriver, peak T1 for maximum signal (or noise). Once this step is complete, background noise should be noticeably higher with an antenna connected than without.

That's it - you're on the air!

Troubleshooting the "SW-40+";

The "bugs" you're most likely to encounter often turn out to be caused by the simplest of problems. If your "SW-40+" doesn't play, the following general suggestions may be helpful:

"It works better plugged in!"

We've all heard that expression before, but unfortunately it's true. Ensure that DC power is getting to the SW-40+. A board with no voltage anywhere probably isn't getting power.

"The headphones are silent!"

It's probably the same as above- an interconnect problem. The 1/8" (3.5mm) jacks in particular are trouble-prone.

- Check once more for solder bridges and missing solder joints. Probing a suspect section of the circuitry with a fingertip or

insulated tool will sometimes bring a stubborn circuit to life- if so, check again for a bad connection!

Of the returns I see, about 85% of the problems are caused by cold solder joints, 5% by solder bridges and 5% due to incorrect resistor installation. That leaves only 5% for all the other problems put together! 'Nuff said.

- Ensure that the ICs are installed in the correct location and with the right orientation.

- Likewise ensure that the transistors and all diodes are installed with the correct orientation.

- If you don't turn up anything with the above steps, see the troubleshooting schematic on the last page of this manual. Using a DVM, check the circuit points noted on the drawing against your "SW-40+" to confirm that the DC voltage readings are all in order.

Here's a rule of thumb for the troubleshooting voltages: I've supplied the nominal voltage readings, but there's some unit-to-unit variation. As an overall guideline, a 20% variation is an

acceptable tolerance. If you're making use of this schematic, "something's broke", and things don't generally break just a little- you're looking for the obvious departures from the published values.

The troubleshooting schematic also lists AC voltage readings in case you have access to an oscilloscope or have a hi-impedance input RF probe. Readings are given in Volts p-p.

 The figure below illustrates IC pinout. The "pin 1 at lower left" convention applies to all Dual-Inline-Package (DIP) ICs.

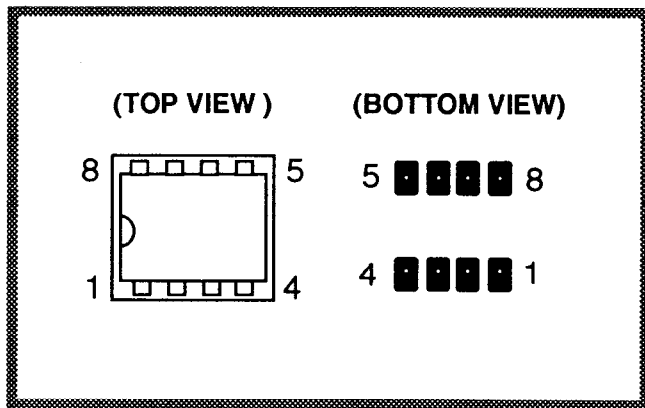

"Strange but True"- In general, the ICs themselves shouldn't be prime suspects during the troubleshooting process. Despite their complexity, they're very reliable, and I've had to replace these parts at the rate of only 1 for every thousand or so shipped!

If those steps don't turn up something, here are some additional steps to try:

Receiver

- Touching either of the 10K resistor leads to the left of the AF Amp IC (U4) should cause an easily-audible hum or buzz in the headphones. If not, and Vr (the 8V supply) is OK, the NE5532 op amp (U4) is suspect.
- Touching an antenna wire to the 470Ω resistor to the left of U3 (product detector) should cause shortwave "crud" to be audible in the headphones. Also, a signal source such as your main station transmitter (on minimum power, please!) should

provide a plainly audible signal when you transmit a string of CW characters just above or below the 4.000 Mhz IF frequency. Do not connect the main station transmitter to the "SW-40+"! - stray leakage is sufficient. Similarly, you should be able to hear the BFO at about 4000 Khz on your main station receiver. If not, these steps point to a problem with U3 or its associated BFO components (Y4 and C17-18).

• Transmitter

Be sure a load is connected anytime you're troubleshooting the transmitter.

- Verify that the keying switch Q3 supplies 12V to the transmit mixer (U5) and Buffer/driver (Q4,Q5) stages when the "Key" input is grounded. Note that the voltage reading at pin 8 of U5 should be 7.1 - 7.9 volts. No-voltage during key-down suggests that Q3 is bad or that D11 is installed backwards.

- Touching a screwdriver to Q6's case (collector) should yield a distinct (key-down) increase in signal received on your "big-rig" receiver. If not, suspect Q6.

If you want to change the sidetone pitch, increasing the value of C29 raises the sidetone pitch (and Tx offset) and decreasing that cap lowers it.

Don't panic!

. . . and don't smash your "SW-40+" against a wall! If all else fails, contact me for further technical support:

Dave Benson, NN1G
80 East Robbins Ave.
Newington CT 06111
(860-667-3536)
e-mail: bensondj@aol.com

Troubleshooting / Alignment is available for a \$25 fee. The unit will be returned to you in working condition and will include a troubleshooting report. Price includes return shipping.

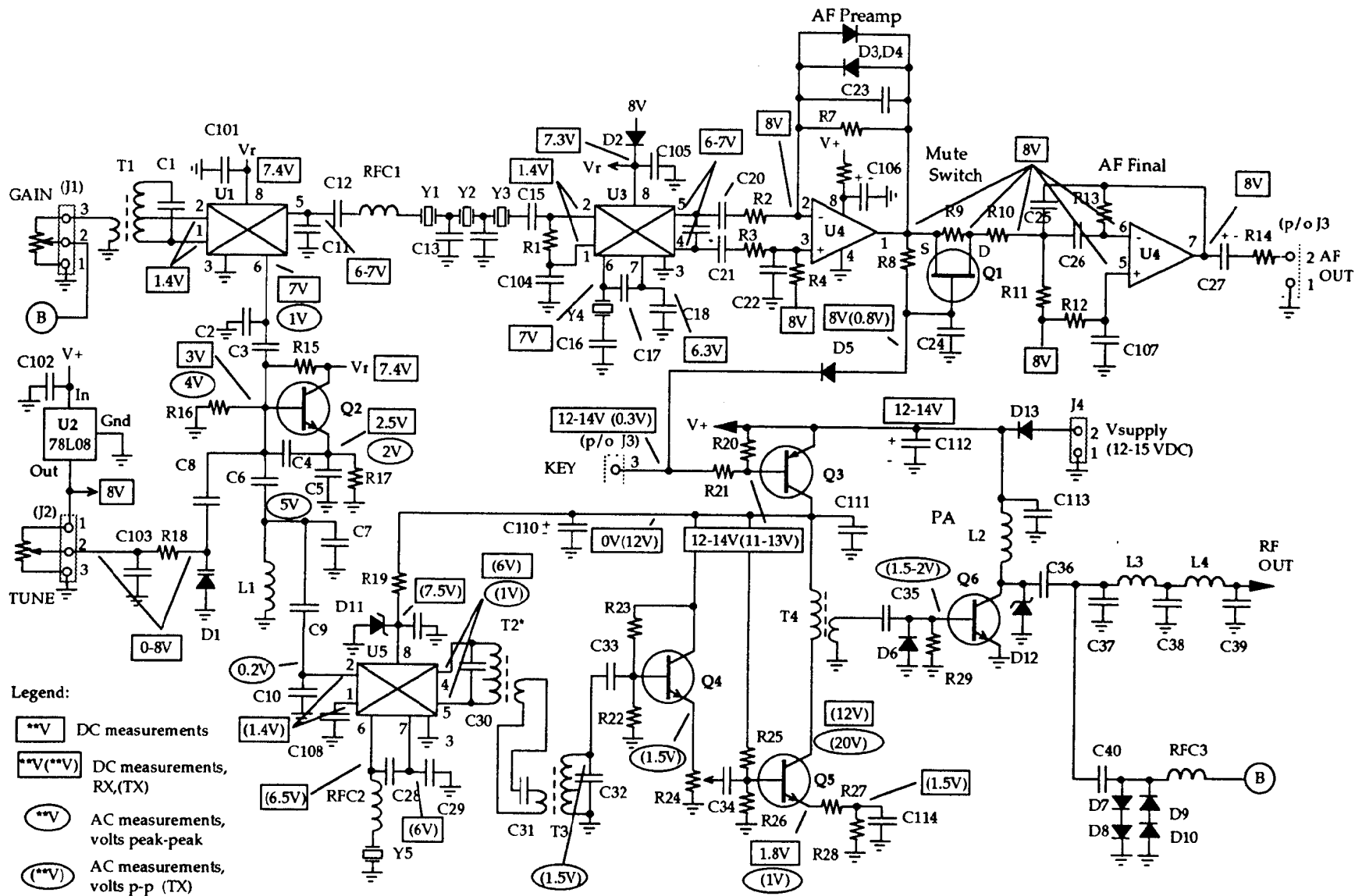

- Legend:**
- **V** DC measurements
 - **V(**V)** DC measurements, RX,(TX)
 - (**V)** AC measurements, volts peak-peak
 - (**V)** AC measurements, volts p-p (TX)

// readings "downstream" of TX drive pot R24 are for maximum drive setting.

(note: probe capacitance disturbs this reading)

Troubleshooting the "SW-XX+" Transceiver

SMALL WONDER LABS™

3/10/98

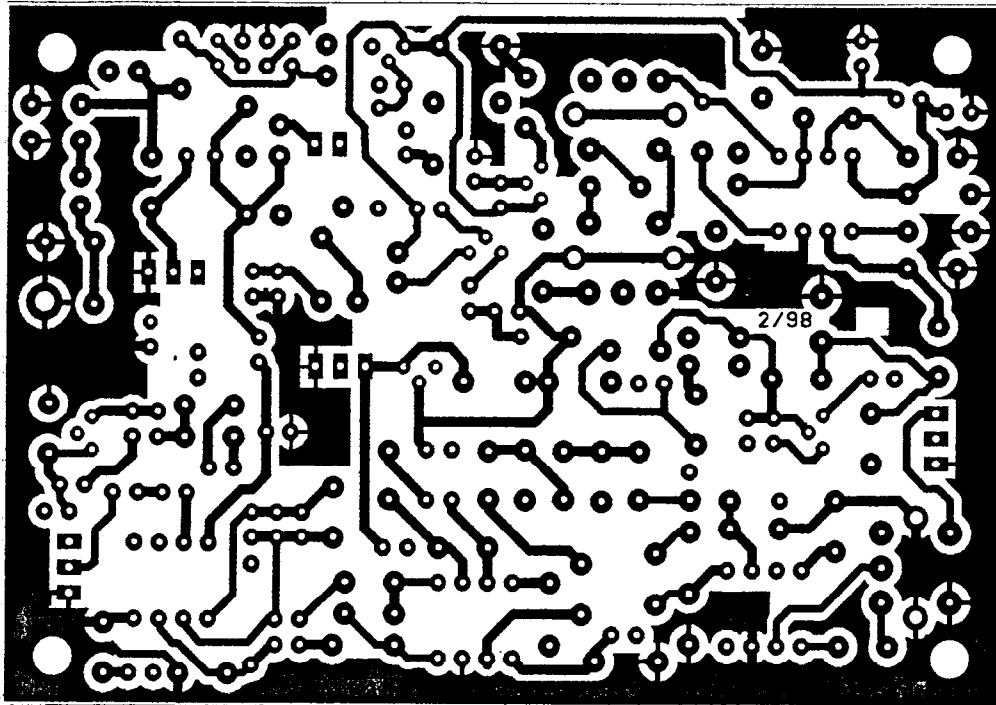

Bottom (solder) layer view